

Sprayers

A full range of high performance sprayers for construction chemicals. Suitable for use with mould oils, release agents and curing membranes. We recommend that all sprayers are cleaned through after use with Cleaning Fluid (RCF25)



Code	Item	Size
MS11	Metal Spray	11 Litre
PS10	Plastic Sprayer	10 Litre
KSS15	Knapsack Sprayer	15 Litre
RCF25	Cleaning Fluid	25 Litre

COLUMN FORMWORK

Cardboard Disposable

An economical, single use spiral wound, cardboard column former. Manufactured to a high standard and complete with a PVC liner, to give a smooth finish to concrete surfaces. Supplied with a built-in rip cord for ease of stripping. Columns are made to order and can be supplied in any required height up to the maximum recommended. Used mainly for in-situ concrete pour application. Full brochure upon request.



Code	Internal Diameter mm	Wall Thickness mm	Weight per metre kg	Max. Recom. Height of Continuous Pour metre
CF200	200	5.0	2.09	12
CF250	250	5.0	2.59	12
CF300	300	5.0	3.11	10
CF350	350	5.0	3.68	10
CF400	400	6.0	4.99	9
CF450	450	6.0	5.67	8
CF500	500	7.0	7.36	8
CF550	550	7.0	8.04	8
CF600	600	7.5	9.51	8
CF635	635	7.5	9.94	7

Plastic Disposable

A disposable single use, fully waterproof column shutter providing a smooth concrete finish. The column shutter can be manufactured in virtually any diameter from 200-1200mm. The columns can be stored openly on site without any detrimental effect.



Code	Item
PCF	Plastic Column Shutter

Available 200mm – 1200mm diameter

Steel Re-usable

For re-use applications, column shutters can be manufactured to order from Steel. Supplied with propping points and grout check seals. Prices on application.

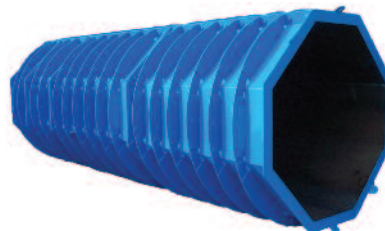

Code	Item
SCF	Steel Column Shutter

Polystyrene Re-usable

Manufactured from high density polystyrene with a proplex liner to give a smooth finish. Can be re-used up to four times. Further information and prices on application



Code	Item
PCS	Polystyrene Column Shutter

NOEplast TEXTURED FORMLINER

NOEplast textured form liners are used extensively to give plain concrete structures a patterned and visually more acceptable finish.

The NOEplast range of liners offers over 100 different standard type patterns, ranging from a simple sawn board effect to complicated and realistic rock type finishes. Other designs can be custom created to meet your specific requirements and can be designed to match an existing concrete finish or profile.

Manufactured from a durable PVC/Rubber compound, NOEplast formliners are suitable for multiple reuses.

For further information please contact our sales office.

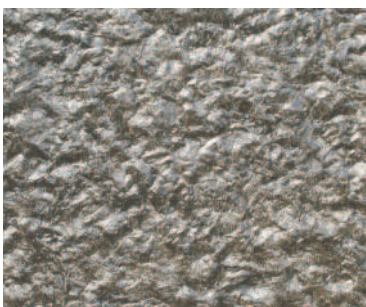

GENERAL PRODUCTS

Standard and Flexible Road Forms

Manufactured in 3 metre lengths. All standard road forms are square edged and have holes at 300mm c/c for dowel bars. Available for both sale and hire. Special sizes can be made to order.



Code	Item	Size m x mm
RF 100	Standard	3 x 100
RF 150	Standard	3 x 150
RF 200	Standard	3 x 200
RFF 100	Flexible	3 x 100
RFF 150	Flexible	3 x 150
RFF 200	Flexible	3 x 200

Road Form Stakes

Smooth finish with forged points.



Code	Size mm
RFS 18	450 x 22
RFS 24	600 x 22

Fencing Pins

A mild steel pin, pointed at one end, and with a curled lamp hook on the other. Ideal for supporting safety barrier fencing.



Code	Size m x mm
FP 12	1.35 x 12.00

Adjustable Steel Props

Threaded portion is friction-welded to the outer tube to produce a lighter-weight prop.

Head and base plates are specially profiled to ensure safe and secure stacking.

Outer tube: 60.3 mm diameter
Inner tube: 48.3 mm diameter

PIN is manufactured from 080M40 (EN8) to BS970.

Manufactured to BS4047 and tested to BS5507



Code	Standard Prop	Closed (M)	Open (M)	Weight (kg)
SP0	No 0	1.041	1.829	11.28
SP1	No 1	1.753	3.124	16.34
SP2	No 2	1.981	3.352	17.48
SP3	No 3	2.590	3.962	20.20
SP4	No 4	3.200	4.876	23.84

Trench Struts

Safe, simple adjustable steel struts for bracing trench linings and for shoring low level, single faced formwork set-ups. Inner remains captive in the outer.



Code	Size	Closed m	Open m	Approx. Weight Kg
TS0	0	0.32	0.47	5.0
TS1	1	0.49	0.73	7.0
TS2	2	0.69	1.09	9.0
TS3	3	1.03	1.73	13.0

Steel Manhole Shutters

The adjustable steel manhole shutter that gives a full 150mm of concrete cover on all size manhole rings using a combination of only two widths of panels.

Two heights: 900mm and 1800mm.

Rapid positive fixing with tie rods and hexagon nuts.

The two different size sections will accommodate any size manhole ring from 675mm to 2700mm and give a minimum concrete cover of 150mm.



Internal manhole shutters also available, manufactured to order.

Code	Item
MH 900A	900mm high large panel
MH 900B	900mm high small panel
MH 1800A	1800mm high large panel
MH 1800B	1800mm high small panel

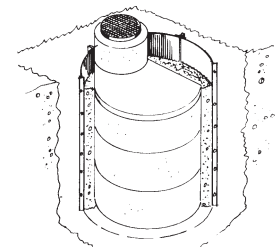

LIFTING LOOPS AND SOCKETS

Cast-In Lifting Socket

Cast-in lifting sockets provide a safe means of lifting concrete beams, mainly in precast applications.

The sockets are cast into wet concrete, in preparation for the acceptance of the lifting loop after curing.



Code	Safe Working Load Tonne	Model d x h	Pack
LSC 1260	0.5	RD 12 x 60	500
LSC 1680	1.2	RD 16 x 80	250
LSC 2095	2.0	RD 20 x 95	150
LSC 24100	2.5	RD 24 x 100	100
LSC 30150	4.0	RD 30 x 150	50

Lifting Loops

Lifting loops with a pressed on socket with thread. For use with lifting sockets. Complete with test certificates.



Code	D x E	H mm	Load tonne	Pack
LL12	12 x 22	155	0.5	50
LL16	16 x 27	155	1.2	50
LL20	20 x 35	215	2.0	25
LL24	24 x 37	255	2.5	25
LL30	30 x 50	300	4.0	10

CHANNEL SYSTEMS

21/19 Apex Channel

A self anchoring stainless steel cast in channel, used for casting into concrete walls for the later fixing of brick ties for outer face cladding. The channel is supplied with a polystyrene infill to prevent the ingress of concrete and also has nail holes to aid fixing to the formwork.



Code	Item	Length mm
AC21191	Apex Channel	100
AC21193	Apex Channel	3000

25/15 Frame Fix Ultra Channel

A stainless steel channel specifically designed to accommodate brickwork cladding back to steel framed structures. Supplied in 2700mm lengths, the channel system is pre-drilled at 112.5mm centres and is also complemented by a range of channel ties to suit.

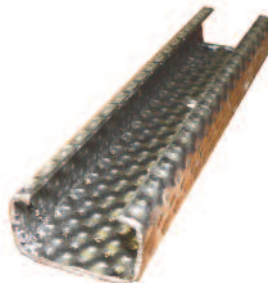

Code	Item	Length mm
FF2515	Frame Fix Ultra	2700

Channel Ties

A full range of channel ties are available to suit both the Apex and Frame Fix Channels, with various solutions to meet most design requirements. Please contact our sales office for full details.



Code	Item	Length mm
CT100	Channel Tie 100	100
CT150	Channel Tie 150	150
CT200	Channel Tie 200	200

INFORM (UK) LIMITED TERMS AND CONDITIONS

1 Definitions

- 1.1 In these conditions, unless the context requires otherwise:
'Company' Inform (UK) Limited (CRN:01572026), whose registered office is at John Dean House, Wellington Road, Burton upon Trent, Staffordshire, DE14 2TG, or any successor, assignee or subsidiary of Inform (UK) Limited;
'Conditions' the terms and conditions of trading set out in this document;
'Customer' the person who buys or agrees to buy and/or hire the goods from the Company;
'Delivery Date' the date specified by the Company when the Goods are to be delivered;
'Equipment' the articles which the Customer agrees to hire from the Company;
'Goods' the articles which the Customer agrees to buy and/or hire from the Company;
'Hire Period' the period commencing when the Customer takes physical possession of and holds the Equipment on hire (including Saturdays and Sundays and Bank Holidays) and ending upon the happening of any of the following events: (i) the physical return of the Equipment by the Customer into the Company's physical possession; or (ii) the physical repossession or collection of the Equipment by the Company;
'Price' the price for the Goods excluding carriage, packing, insurance and VAT; and
'Rental' the Company's charging rate for the hire of the Equipment and to be paid by the Customer to the Company during the Hire Period and any extension therefore excluding carriage, packing, insurance and VAT.

2 Basis of Contract

- 2.1 These Conditions shall apply to all contracts for the sale and/or hire of Goods/Equipment by the Company to the Customer to the exclusion of all other terms and conditions including any terms or conditions which the Customer may purport to apply under any purchase order, confirmation of order or similar document.
2.2 All orders for Goods and/or the hire of the Equipment shall be deemed to be an offer by the Customer to purchase Goods or hire Equipment pursuant to these Conditions. Acceptance of delivery of the Goods and/or Equipment shall be deemed conclusive evidence of the Customer's acceptance of these Conditions.
2.3 Any variation to these Conditions (including any special terms and conditions agreed between the parties) shall be inapplicable and shall not bind unless agreed in writing and signed by an authorised representative of the Company.
2.4 Any advice or recommendation given by the Company or its employees or agents to the Customer or its employees or agents as to the storage, application or use of the Goods and/or Equipment which is not confirmed in writing by the Company is followed or acted upon entirely at the Customer's own risk. The Company shall not be liable for any losses sustained by the Customer following the said advice or recommendation.

3 Price, Rental and Payment

- 3.1 The Price and/or the Rental shall be the Price or Rental referred to in the Company's Quotation and/or other documentation. Any Price and/or Rental referred to in a quotation shall only be valid for 30 days. The Price and/or Rental is exclusive of VAT for which the Customer shall be additionally liable and which shall be due at the rate ruling on the date of the Company's invoice.
3.2 The Company reserves the right, by giving notice in writing prior to the Delivery Date, to alter the Price and/or the Rental to reflect any increase in costs to the Company due to factors beyond the Company's reasonable control, and change in Delivery Dates, quantities or specification for the Goods and/or Equipment by the Customer, and/or any delay caused by any instructions of the Customer.
3.3 Except where otherwise stated in Clause 12, Goods and/or Equipment supplied are ex works. In the event that the Company agrees to deliver the Goods and/or Equipment, the Customer shall be liable for the costs of transportation, packaging and insurance.
3.4 The cost of pallets, bins, packaging, cases and returnable containers will be charged to the Customer in addition to the price of the Goods and/or Equipment.
3.5 Payment of the Price and/or Rental (together with VAT) shall be due within 30 days of the date of the Company's invoice and/or in accordance with the provisions of Clause 12 in the event that the Goods are required for shipment. Time for payment shall be of the essence of the contract. If the Customer fails to make any payment in full on the due date the Company may charge the Customer any reasonable additional administration costs and/or interest (both before and after judgment) on the amount unpaid at the rate of 2% per calendar month with any part of a calendar month being treated as an entire month for the purpose of calculating interest. Such interest shall be compounded with monthly rests.
3.6 The Company shall be entitled to appropriate payment made by the Customer in respect of any Goods and/or Equipment in settlement of invoices or accounts which are overdue and in respect of such Goods and/or Equipment as the Company may in its absolute discretion think fit, notwithstanding any appropriation intended by the Customer to the contrary.
3.7 The Customer will make all payments due to the Company without any set-off, deduction, counterclaim or other withholding of monies.
3.8 The Company may set a reasonable credit limit for the Customer. The Company reserves the right to terminate or suspend the contract to the Customer if allowing it to continue would result in the Customer exceeding its credit limit or the credit limit has already been exceeded.

4. Terms of Hire

- 4.1 If the Customer mixes the Equipment with the Customer's own equipment, the Company's decision as to subsequent separation and identification of the Equipment shall be final.
4.2 Risk in the Equipment shall pass immediately to the Customer when the Equipment leaves the physical possession or control of the Company. Risk in the Equipment shall not pass back to the Company from the Customer until the Equipment is back in the physical possession of the Company. This shall apply even if the Company has agreed to cease charging the Rental.
4.3 Title in the Equipment shall remain at all times with the Company. The Customer has no right title or interest in the Equipment except that the Equipment is hired to the Customer. The Customer must not deal in any way with the title or any interest in the Equipment. This shall include without limitation, selling, assigning, parting with possession, charging, pledging, mortgaging, securing, hiring exerting a lien or lending.
4.4 The minimum Hire Period is 14 days. The Customer shall pay to the Company during the Hire Period the Rental in the amounts and at the intervals specified by the Company. Payment shall be made in accordance with Clause 3 above. Provided that the Customer shall not be in default of its obligations under these Conditions, the Customer shall be entitled to terminate the hire on giving the Company not less than

3 days notice in writing to that effect and by paying the total Rental which would have been due for the total Hire Period requested by the Customer originally and by returning the Equipment (at the Customer's expense) to the Company in good repair and condition. If the Customer (i) fails to pay any Rental or other sums due in full when due or (ii) the Company has good reason to doubt the Customer's credit worthiness or (iii) the Customer shall do or cause to be done or permit or suffer any act or thing whereby the Company's rights in the Equipment are prejudiced or any event referred to in Condition (Termination) 14.1 occurs then the Customer shall be deemed to have repudiated the Contract and the Company may at any time thereafter accept that repudiation and the Contract will terminate forthwith and for all purposes, without prejudice to the Company's rights under these Conditions.

- 4.5 Where the hire of Equipment is to a Customer who is an individual and the hire would be covered by the Consumer Credit Act 1974 (as amended) the duration of the Hire Period shall not exceed 3 months. Accordingly the hire of any Equipment is not covered by the Consumer Credit Act 1974 (as amended).
4.6 The Company reserves the right to vary the Rental at any time during the Hire Period. If the Rental is revised, the Company shall give the Customer 28 days notice of the revised Rental and shall be entitled to charge the revised Rental at the expiry of the 28 day period.
4.7 Any Equipment proved to be defective when delivered will be replaced free of charge by the Company and Rental will be suspended until the replacement is available, and the Company will not levy any delivery charges in respect of such replacement.

5. Use of Equipment

- 5.1 The Customer shall not permit the Equipment or any part thereof to be used for any purpose for which it is not expressly designed and the Customer further agrees that it will not:-
5.1.1 without the prior consent of the Company affect either itself or allow or enable any third party to make any mechanical or other Modification to the Equipment
5.1.2 either itself or allow or permit any third party to make any alterations or additions to the Equipment;
5.1.3 remove or interfere with any identification marks or plates affixed to the Equipment nor attempt or purport to do so nor permit any such removal or interference to be effected;
5.1.4 deface the Equipment nor add or erect any painting, sign-writing, lettering or advertising to or on the Equipment; and/or
5.1.5 sub-let or part with possession of any of the Equipment without the prior written consent of the Company.

6. Lost Equipment

- 6.1 The Customer shall notify the Company forthwith of any Equipment which is lost or damaged.
6.2 Upon receipt of notice of loss or damage pursuant to Condition 6.1 or if the Equipment is not returned to the Company or the Company has reason to suspect that the Equipment has been lost or damaged beyond repair or where after reasonable notice from the Company (being not more than 7 days in any event) the Customer shall be unable to produce the Equipment such Equipment shall be treated as lost and the Company shall invoice the Customer for a sum equal to: (i) the replacement cost of the Equipment on a new for old basis less the amount paid to the Company under any policy of insurance taken out in accordance with these Conditions; plus (ii) the Rental for the period from the date of the notice in Condition 6.1 or the date that the Company's suspicion arose under this Condition, until the date of the receipt in full in cash or cleared funds by the Company of the amount representing the replacement cost of the Equipment.
6.3 All Equipment shall remain the property of the Company notwithstanding that it may have been lost or treated as lost pursuant to Condition 6.2. The Customer shall at all times use its best endeavours to assist the Company to resume possession of the Equipment. Where Equipment previously treated as lost is returned to the Company or recovered and taken back into use by the Customer the Customer shall be entitled to a credit equal to the sum paid in respect thereof pursuant to Condition 6.2 and the Company shall be entitled to charge the Customer Rental in respect of the Equipment as if the same had never been lost but had remained in the possession of the Customer.

7. Damage to Equipment

- 7.1 Unless proven to be due to negligence on the part of the Company the Customer shall be solely responsible for loss or damage to the Equipment.
7.2 The Company shall have the right itself to repair or have repaired any Equipment which is the subject of an accident. If the Company does not choose to do so the Customer shall be liable to reinstate or repair the Equipment at its own expense and shall continue to pay the Rental in respect of such Equipment during such reinstatement or repair.
7.3 In accordance with Condition 7.4, if the Equipment is returned to the Company in a condition other than that in which it was provided to the Customer a charge for cleaning, re-conditioning, renewing or replacing the Equipment will be made where considered necessary by the Company. The Customer will be notified in writing of such damage and the Equipment will be available for inspection for 7 days from the date of such notice.
7.4 The Customer is responsible for the proper handling, dismantling, storage, maintenance and cleaning of the Equipment. Loss or damage howsoever caused (excluding fair wear and tear) to the Equipment will, without prejudice to any other remedies the Company may have, render the Customer liable to a charge for the cost of any repair and/or cleaning or maintenance required to return the Equipment to a condition fit for re-hire and the Rental until such repairs, maintenance or cleaning have been completed. Damage shall include wear and tear beyond normal use such as breakages, cuts or drillings.

8. Return of the Equipment

- 8.1 Without prejudice to the foregoing or to the Company's claim for any arrears of Rentals or damages for any breach by the Customer of these Conditions or any other rights of the Company, the Company and/or its authorised representatives may at any time after termination or expiry of the Hire Period without notice retake possession of the Equipment and for such purpose enter upon any premises belonging to or in the occupation or control of the Customer and the Customer shall be responsible for all costs, charges and expenses so incurred in the Company retaking possession of the Equipment as aforesaid. The Customer shall also bear the reasonable costs incurred by the Company at any time in ascertaining the whereabouts of the Equipment and/or the Customer.

- The Equipment must be returned to the Company bundled, palletted and cleaned. Failure to do so shall render the Customer liable to a charge in addition to the Rental for the cost to the Company of so bundling, palletting or cleaning.
- 8.3 Where the Company has agreed to collect the Equipment instructions to collect must be given in writing and must be received by the Company at least 48 hours before collection is required. Such written notice will be the only recognised proof of collection instructions to the Company. In any such case, the Customer shall be responsible for all loading of the Equipment. The Equipment will not be received by Company before 8.30am and after 4.00 p.m. on Monday to Friday. No returns will be accepted on Saturday or Sunday. Where the delivery or collection of Equipment is effected by the Company the Customer will pay a delivery or collection charge at the Company's standard transport rate applicable at the date of delivery or collection. Such charge shall include any wasted journey or transport time incurred by the Company in attempting reasonably to comply with the express or implied requirements of the Customer.
- 8.4 Notwithstanding any instructions given by the Customer to the Company for collection of the Equipment, the Hire Period will not be deemed to have ended and Rental shall continue to accrue unless or until the Equipment is back in the Company's physical possession and control.
- 8.5 For so long as the Company is not in physical possession or control of the Equipment whether or not the Customer has notified the Company and is awaiting collection, the provisions of these Conditions shall, in their entirety, continue in full force and effect and the Rental will continue to accrue for such period notwithstanding expiry of the specified Hire Period and the Customer shall continue to use their best endeavours to safeguard the Equipment against loss or damage.
- 9 Specification of Goods**
- 9.1 The Goods will be supplied in accordance with the tolerances of dimension, quality and design criteria specified on the Company's final drawings and quotations. Tolerances specified on the Customer's documentation or enquiry do not form part of the Contract unless expressly agreed in writing by the Company before or at the time of acceptance of the Customer's Order.
- 9.2 The Customer is responsible for checking the quotation and satisfying itself that any specification given is accurate and adequate for the Goods.
- 9.3 The Customer shall be responsible for the accuracy of all drawings, designs and specifications submitted by the Customer to the Company and the Customer shall be responsible for all costs arising from any omissions, errors or inaccuracies in the said drawings, designs, or specifications and shall indemnify and hold harmless the Company against any liability of the Company arising as a result of any such omissions, errors or inaccuracies.
- 9.4 If there is an error in the specification made by the Company for the Customer then where that error is material and it has been relied upon by the Customer, the Customer may cancel that part of the Contract which is affected by the error without liability due to the cancellation.
- 9.5 The Customer shall be responsible for obtaining all necessary consents, licences and/or permits in relation to the purchase of the Goods, the purposes for which the Goods are to be used and the manor of such use.
- 9.6 The Customer agrees to indemnify and keep indemnified the Company against any and all claims, losses, expenses, proceedings, actions, awards, liabilities, costs (including legal costs on a full indemnity basis and increased administration costs) expenses, damages and any other losses and/or liabilities arising out of the Company's use of specifications, details and/or drawings supplied by the Customer.
- 9.7 As regards any Goods supplied by the Company, the Company shall be deemed not to have any knowledge of the particular purpose, use or market for which the Goods are required unless such purpose, use or market is expressly stated in the Contract and [without limiting the generality of the foregoing] any timber or plywood Goods supplied by the Company or not tested by the Company nor sold by it as being fit for a particular purpose.
- 9.8 The Company reserves the right to make changes to the specification of the Goods as required from time to time by law, applicable safety requirements or manufacturing requirements provided that they do not have a material adverse effect on the quality and/or performance of the Goods.
- 9.9 No drawings, descriptive matter, weights, dimensions or shipping specifications issued by the Company for the manufacture of the Goods and/or Equipment nor the descriptions and illustrations contained in the Company's Goods Manufacturers catalogues, price lists or other promotional material will form part of the Contract nor be regarded as a Warranty or representation relating to the Goods and/or Equipment.
- 9.10 If the Company does make changes to the specification of the Goods which have a material adverse effect then the Customer shall have the right to cancel the Contract without liability.
- 10 Delivery of the Goods**
- 10.1 Delivery of the Goods shall be deemed to have taken place once the Goods have been made available for despatch by the Company, unless otherwise agreed in writing. The Company will endeavour to deliver the Goods within the time agreed however time of delivery is not of the essence. Notwithstanding that the Company may have delayed or failed to deliver the Goods (or any of them) promptly the Customer shall be bound to accept delivery and to pay for the Goods in full provided that delivery shall be tendered at any time within 3 months of the Delivery Date. Delay in delivering shall not entitle the Customer to terminate the contract.
- 10.2 Unless otherwise agreed the Customer will make arrangements for the carriage of the Goods. If the Company makes arrangements for the carriage of the Goods, delivery will be deemed to have taken place once the carrier collects the Goods from the Company's premises and the Customer shall be responsible for the unloading of the Goods.
- 10.3 Where the Goods are carried by the Company's own transport, or by a carrier on behalf of the Company, and there has been damage to or loss of the Goods, the Customer must notify to the Company any loss or damage to the Goods within **48 hours** of receipt and the Goods shall be held for inspection to enable a claim to be made on the carrier. The Customer shall immediately notify the Company if the Goods are not received within **48 hours** of the date of the invoice. Any claim for damaged Goods or shortages or non-delivery shall be notified to the carriers by the Customer in the manner and within the appropriate time limit prescribed by the carriers' terms and conditions. In the event of the Customer's failure to comply with the terms of 10.3, they shall be deemed to have accepted the Goods and any claim by the Customer will be waived and barred. Where the Customer rejects the Goods pursuant to 10.3 they shall nevertheless be obliged to unload and store the Goods.
- 10.4 The Company may deliver the Goods in instalments, and if so each delivery shall constitute a separate contract. Failure by the Company to deliver any one or more of the instalments shall not entitle the Customer to terminate the whole contract.
- 10.5 If the Customer fails to take delivery of the Goods or fails to give the Company adequate delivery instructions then, without prejudice to any other right or remedy available, the Company may:
- 10.5.1 Store the Goods until actual delivery and charge the Customer for the reasonable costs (including insurance) of storage; or
- 10.5.2 Sell the Goods at the best price readily available and (after deducting all reasonable storage and selling expenses) account to the Customer for the excess over the Price under the contract or charge the Customer for any shortfall below the Price of the contract.
- 10.6 The Customer shall be deemed to have accepted the Goods 48 hours after delivery to the Customer. After acceptance the Customer shall not be entitled to reject Goods which are not in accordance with the contract.
- 11 Title and Risk of the Goods**
- 11.1 Risk in the Goods shall pass to the Customer on delivery of the Goods and delivery shall be in accordance with Clause 10 above.
- 11.2 The Company shall retain title and ownership of the Goods until it has received payment in full in cash or cleared funds of all sums due and/or owing for all Goods and/or Equipment supplied to the Customer by the Company under this Contract and any other agreement between the Company and the Customer.
- 11.3 Until payment in full of the price for all Goods/Equipment supplied to the Customer has been received by the Company, the Goods shall be stored separately from any products or goods belonging to the Customer or any other third party must be clearly marked and identified as being the Company's property. The Customer agrees that the Company's employees and/or agents shall be entitled to enter the Customer's premises at any time to check compliance with this clause.
- 11.4 Until title of the Goods has passed to the Customer, the Customer shall keep the Goods insured for the price at which the Goods were sold to the Customer against all insurable risks and shall procure that the Company's interest is noted on such a policy of insurance. The Customer shall account to the Company for any proceeds of such policy of insurance in relation to the Goods upon receipt of the same. Any monies received from the Customer by the Company in accordance with this clause shall not discharge the Customer's liability to pay the price for the Goods plus interest accrued in accordance with Clause 3.5 but shall be set off against any such liability.
- 12 Export**
- 12.1 "Incoterms" means the international rules for the interpretation of trade terms of the International Chambers of Commerce as in force at the date when the Contract is made. Unless the context otherwise requires, any term or expression which is defined in or given a particular meaning by the provisions of Incoterms shall have the same meaning in these Conditions. If there is any conflict between the Incoterms and these Conditions the latter shall prevail.
- 12.2 Where the Goods are supplied for export from the United Kingdom, the provisions of this Condition 12 shall (subject to any special terms agreed in writing between the Customer and the Company) apply notwithstanding any other provision of these Conditions.
- 12.3 The Customer shall be responsible for complying with any legislation or regulations governing the importation of the Goods into the country of destination and for the payment of any duties thereon.
- 12.4 Unless otherwise agreed in Writing between the Customer and the Company, the Goods shall be delivered FOB. The air or sea port of shipment and the Company shall be under no obligation to give notice under Section 32(3) of the Sale of Goods Act 1979.
- 12.5 The Customer shall be responsible for arranging for testing and inspection of the Goods at the Company's premises before shipment. The Company shall have no liability for any claim in respect of any defect in the Goods which would be apparent on inspection and which is made after shipments, or in respect of any damage during transit.
- 12.6 Payment of all amounts due to the Company shall be made as follows:-
- 12.6.1 in respect of new Customers, or Customers refused a credit account, cleared funds are required in advance of export for the Price. Alternatively, the Company may at their absolute discretion accept a letter of credit with payment being 30 days after documentation;
- 12.6.2 in respect of the Customers permitted a credit account, payment shall be due within 30 days from the date of the Company's invoice unless otherwise agreed in writing
- 12.7 The Customer undertakes not to offer the Goods for resale in any country notified by the Company to the Customer or to sell the Goods to any person if the Customer knows or has reason to believe that that person intends to resell the Goods in any such country.
- 13 Cancellation**
- 13.1 If the Customer cancels, extends or delays or purports to cancel, extend or delay the Contract or part thereof, or fails to take delivery of any Goods at the time agreed (if any) the Customer will be liable (without prejudice to any other rights of the Company to claim damages) to indemnify and keep indemnified the Company against any resulting loss, damage or expense incurred by the Company in connection with the supply or non-supply of the Goods and/or Equipment including but not limited to lost Rental.
- 13.2 If the Company is unable (whether temporarily or permanently) to procure any services or goods necessary to enable it to supply the Goods and/or Equipment or if the supply of Goods and/or Equipment is prevented or hindered by reason of any cause beyond the Company's control, including but not limited to a force majeure, the Company may cancel or suspend performance of the contract by notice in writing to the Customer so far as it relates to Goods and/or Equipment not then supplied and such cancellation or suspension shall not give rise to any claims by the Customer and the Customer shall remain liable to pay for Goods and/or Equipment supplied or hired prior to the date of such cancellation or suspension.
- 14 Termination**
- 14.1 If the Customer:
- 14.1.1 Fails to make any payment to the Company within 30 days of it becoming due (whether demanded or not);
- 14.1.2 breach the terms of this Contract and where the breach is capable of remedy, have not remedied the breach within 14 days of receiving notice requiring the breach to be so remedied;
- 14.1.3 persistently breach the terms of this Contract;
- 14.1.4 pledge or charge any Goods and/or Equipment which remain the Company's property, or cease or threaten to cease to carry on business, or propose to compound with its

- creditors, apply for an interim order under section 252 of the Insolvency Act 1986 or have a bankruptcy petition presented against the Customer, or being a company enter into a voluntary or compulsory liquidation, have a receiver, administrator or administrative receiver appointed over all or any of its assets or any resolution or petition to wind up the Customer (other than for the purpose of a bona fide amalgamation or reconstruction without insolvency) shall be passed or presented or takes or suffers any similar action in any jurisdiction;
- 14.1.5 appears to the Company due to its credit rating to be financially inadequate to meet its obligations under the Contract; and/or
- 14.1.6 appears reasonably to the Company to be about to suffer any of the above events; then the Company shall have the right without prejudice to any other remedies to exercise any or all of the rights set out in Condition 14.2 below.
- 14.2 If any of the events in Clause 14.1 occur in relation to the Customer then:
- 14.2.1 the Company may enter, without prior notice, any premises of the Customer (or premises of third parties with their consent) where Goods and/or Equipment owned by the Company may be and repossess and dispose of or sell any Goods and/or Equipment found which are owned by the Company so as to discharge any sums due to the Company under this Contract or any other agreement with the Customer;
- 14.2.2 the Company may require the Customer not to re-sell or part with the possession of any Goods and/or Equipment owned by the Company until the Customer has paid in full all sums due to the Company under this Contract or any other agreement with the Customer;
- 14.2.3 the Company may withhold delivery of any undelivered Goods and/or Equipment and stop any Goods and/or Equipment in transit;
- 14.2.4 the Company may cancel, terminate and/or suspend without liability to the Customer any contract with the Customer; and/or
- 14.2.5 all monies owed by the Customer to the Company shall forthwith become due and payable.
- 14.3 The Company shall have a lien over all property or goods belonging to the Customer which may be in the Company's possession in respect of all sums due from the Customer to the Company.
- 14.4 Upon the termination of the Contract for any reason if any monies due to the Company from the Customer have not been paid within 14 days of such termination the Company may sell any property or goods over which it has a lien in accordance with Clause 14.3 above (and the Customer agrees that the Company may give good title for such property and/or goods) and shall apply the proceeds of sale firstly in discharging any costs or expenses of sale, secondly in repaying any interest owed by the Customer to the Company, thirdly in payment of any principal sums owed to the Company and fourthly the Company shall account to the Customer for the remainder (if any).
- 14.5 If the Customer declines to accept the Goods and/or Equipment in breach of these conditions the Customer shall pay to the Company as and by way of agreed liquidated damages an amount equal to the Price less the net proceeds received by the Company on reselling the Goods and/or Equipment after deducting the costs and expenses of resale.
- 15 Warranties and Liability**
- 15.1 The Company shall not be liable for any defect in the quality or condition of the Goods and/or Equipment unless the defect would not have been apparent upon a reasonably thorough examination and inspection of the Goods and/or Equipment by the Customer (whether or not such examination or inspection is actually made by the Customer).
- 15.2 Any claim by the Customer based on any alleged defect in the quality or condition of the Goods and/or Equipment or their failure to correspond with specification shall (whether or not delivery is refused by the Customer) be notified to the Company within 7 days from the delivery date or (where the defect or failure was not apparent on reasonable inspection) within a reasonable time after discovery of the defect or failure. If delivery is not refused, and the Customer does not notify the Company accordingly, the Customer shall not be entitled to reject the Goods and/or Equipment and the Company shall have no liability for such defect or failure, and the Customer shall be bound to pay the Price or Rental as if the Goods and/or Equipment had been delivered in accordance with the Contract.
- 15.3 Where any valid claim in respect of any of the Goods and/or Equipment which is based on any defect in the quality or condition of the Goods and/or Equipment or their failure to meet specification is notified to the Company in accordance with these Conditions, the Company shall be entitled to replace the Goods and/or Equipment (or the part in question) free of charge or, at the Company's sole discretion, refund to the Customer the price of the Goods and/or Equipment (or a proportionate part of the price), but the Company shall have no further liability to the Customer.
- 15.4 The Company shall not be liable to the Customer by reason of any representation, or any implied warranty, condition or other term, or any duty at common law, or under the express terms of the Contract, for any indirect or consequential loss or damage, loss of profits and/or damage to goodwill; economic and/or other similar losses; special damages and indirect losses; and/or business interruption, loss of business, contracts, opportunity and/or production costs, expenses or other claims for consequential compensation whatsoever including loss or damage arising in respect of the Customer's liabilities to any third party (and whether caused by the negligence of the Company, its employees or agents or otherwise) which arise out of or in connection with the supply of the Goods or their use or resale (as appropriate) by the Customer, except as expressly provided in these Conditions.
- 15.5 Each of the limitations or exclusions in these Conditions shall be deemed to be repeated and apply as a separate provision for each of (i) liability for breach of contract; (ii) liability in tort (including negligence); (iii) liability for breach of Statutory duty; and (iv) liability for breach of Common Law; except Condition 15.6 which shall apply once only in respect of all the said types of liability.
- 15.6 The Company's total liability to the Customer shall not exceed £1,000,000 (one million pounds sterling).
- 15.7 Nothing in these Conditions shall exclude or limit the Company's liability for death or personal injury due to the Company's negligence or any liability which is due to the Company's fraud or any other liability which it is not permitted to exclude or limit as a matter of law.
- 15.8 The Company shall not be liable to the Customer or be deemed to be in breach of the Contract by reason of any delay in performing, or any failure to perform, any of the Company's obligations in relation to the Goods and/or Equipment, if the delay or failure was due to any cause beyond the Company's control.
- 15.9 In the event of any breach of this contract by the Company the remedies of the Customer shall be limited to damages.
- 15.10 Save as expressly referred to above, and except where the Customer is dealing as a consumer (as defined in the Unfair Contract Terms Act 1977 Section 12 as amended and/or the Unfair Terms in Consumer Contracts Regulations 1999 Regulation 3(1)), all other warranties, conditions or terms relating to fitness for purpose, quality or condition of the Goods and/or Equipment, whether express or implied by statute or common law or otherwise are excluded to the fullest extent permitted by law.
- 15.11 The Customer shall indemnify defend and hold harmless the Company in full against all loss, costs, damages, charges, expenses and other liabilities awarded against or incurred (but excluding any liability to the extent that it is based on any breach of the Company's warranty in Clause 16.2) as a result of or in connection with any claim made against the Company by a third party in respect of any matter caused by the Customer or for which liability has been assumed by the Customer.
- 16. General**
- 16.1 The provisions of the Contracts (Rights of Third Parties Act) 1999 shall not apply to this contract and a person who is not a party to this contract shall have no right under that Act to enforce any term of these Conditions. This shall not apply to any member of the Company's Group who shall subject to the Company's consent, have the right to enforce the terms of these Conditions as though they were a party to them. Any right of a third party to enforce these Conditions may be varied by agreement between the Customer and the Company without the consent of any such third party.
- 16.2 Save for the Customer's obligation of payment under Condition 3 neither party shall be liable for any default due to any act of God, war, civil disturbance, malicious damage, strike, lockout, industrial action, fire, flood, drought, extreme weather conditions, compliance with any law or governmental order, rule, regulation, direction or other circumstance beyond the reasonable control of either party ('Force Majeure Event'). Each party shall give notice forthwith to the other upon becoming aware of a Force Majeure Event, the notice to specify details of the circumstances giving rise to the Force Majeure Event.
- 16.3 Any notice under or in connection with these Conditions of sale shall be in writing and shall be served by first class post or by hand on the party or sent by recorded delivery or e-mail at or to the address of the party set out in these Conditions or at or to such other address as may be subsequently notified by one party to the other in writing.
- 16.4 In the absence of evidence of earlier receipt any notice shall be deemed to be duly served:
- 16.4.1 if delivered personally when left at the address specified in Clause 17.3;
- 16.4.2 if sent by recorded delivery 3 days after posting; and
- 16.4.3 if sent by e-mail or fax, when sent (provided the sender has written proof of successful transmission).
- 16.5 This Agreement constitutes the entire agreement and undertaking between the Company and the Customer with regard to the subject matter of this Agreement, and supersedes all prior discussions, agreements and understandings. The parties further agree that no statements or representations made by either party have been relied upon by the other party in entering into the Agreement.
- 16.6 This Agreement may be amended only by written agreement signed on behalf of the Company and the Customer by a Director thereof or by a person who has been given written authority to sign by a Director thereof.
- 16.7 The Customer shall not assign, transfer or sub-contract any of its rights or obligations arising under, by reason of, or in connection with this Agreement, without the prior written consent of the Company. The Company may assign, subcontract, transfer and/or part with the benefit and/or burden of this Contract in whole or in part without the consent of the Customer.
- 16.8 Failure by the Company to enforce any of the Conditions will not be construed as a waiver of any rights hereunder and no waiver by the Company for any breach of this Contract shall be considered as a waiver of any subsequent breach of the same provision and/or any other provision.
- 16.9 In relation to all obligations of the Customer time of performance is of the essence.
- 16.10 The legal construction of these conditions shall not be affected by their headings which are for convenience of use only.
- 16.11 If at any time any of these conditions is found by any court, tribunal or administrative body of competent jurisdiction to be wholly or partly illegal or unenforceable in any respect that shall not affect or impair the legality, validity or enforceability of any other provision of these conditions.
- 16.12 This contract is subject to the law of England and Wales and the parties submit to the non-exclusive jurisdiction of the English Courts.

BS 8666:2005 Standard Shapes

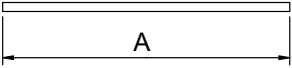
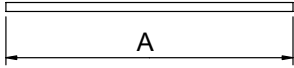
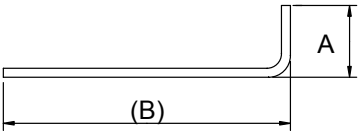
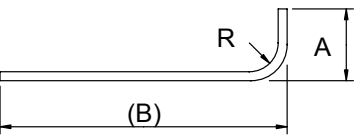
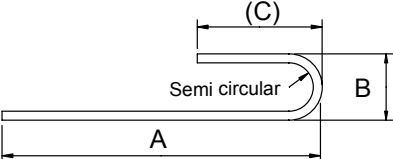
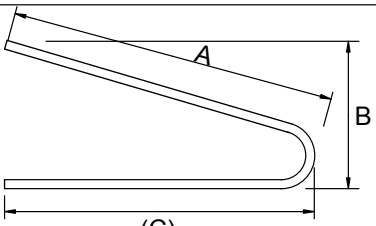
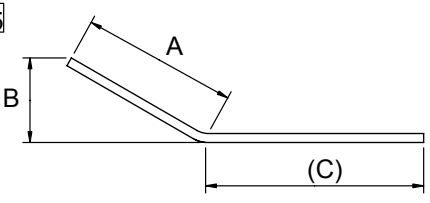
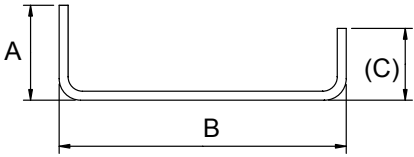
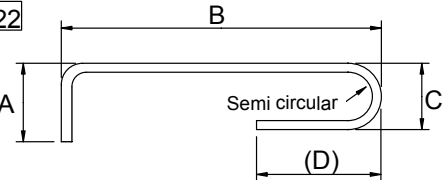
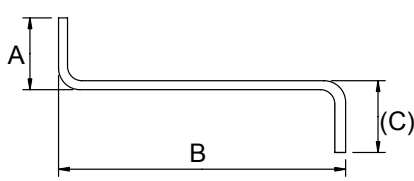
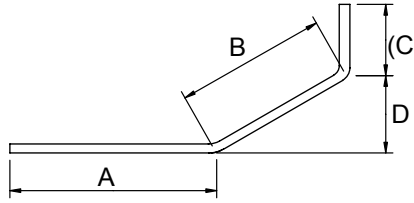
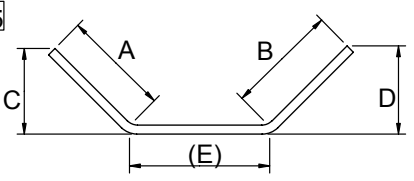
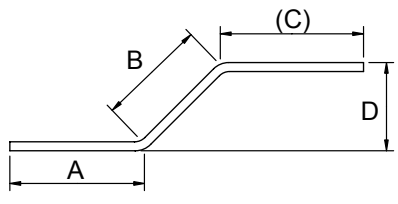
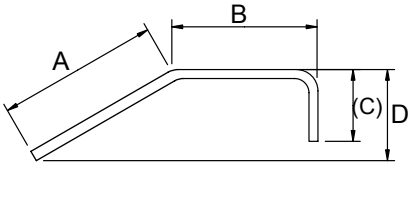
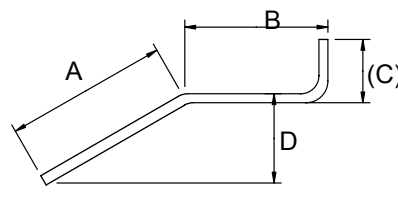
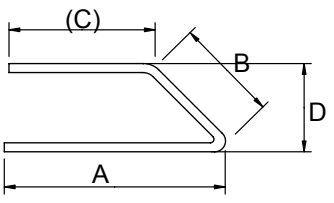
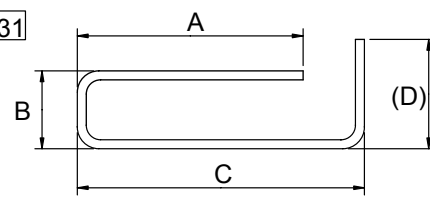
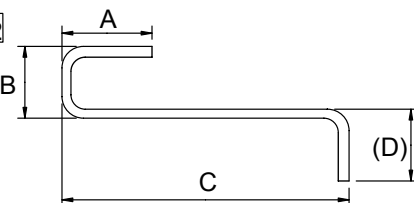
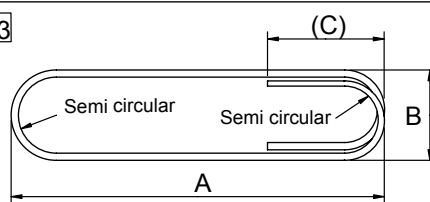
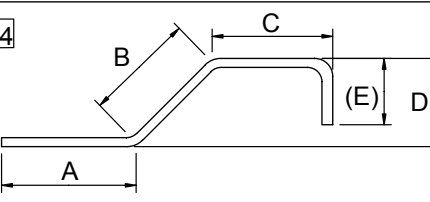
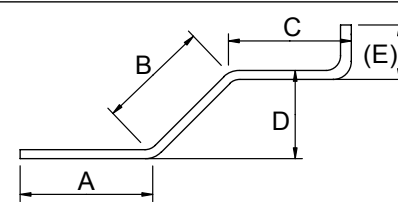
Shape and total length of bar (L) measured along centre-line		
<p>00</p>  <p>$L = A$</p>	<p>01</p>  <p>$L = A$, stock lengths</p>	<p>11</p>  <p>$L = A + (B) - 0.5 r - d$</p>
<p>12</p>  <p>$L = A + (B) - 0.43 R - 1.2 d$</p>	<p>13</p>  <p>$L = A + 0.57 B + (C) - 1.6 d$</p>	<p>14</p>  <p>$L = A + (C) - 4 d$</p>
<p>15</p>  <p>$L = A + (C)$</p>	<p>21</p>  <p>$L = A + B + (C) - r - 2 d$</p>	<p>22</p>  <p>$L = A + B + C + (D) - 1.5 r - 3 d$</p>
<p>23</p>  <p>$L = A + B + (C) - r - 2 d$</p>	<p>24</p>  <p>$L = A + B + (C)$</p>	<p>25</p>  <p>$L = A + B + (E)$</p>
<p>26</p>  <p>$L = A + B + (C)$</p>	<p>27</p>  <p>$L = A + B + (C) - 0.5 r - d$</p>	<p>28</p>  <p>$L = A + B + (C) - 0.5 r - d$</p>
<p>29</p>  <p>$L = A + B + (C) - r - 2 d$</p>	<p>31</p>  <p>$L = A + B + C + (D) - 1.5 r - 3 d$</p>	<p>32</p>  <p>$L = A + B + C + (D) - 1.5 r - 3 d$</p>
<p>33</p>  <p>$L = 2 A + 1.7 B + 2 (C) - 4 d$</p>	<p>34</p>  <p>$L = A + B + C + (E) - 0.5 r - d$</p>	<p>35</p>  <p>$L = A + B + C + (E) - 0.5 r - d$</p>

BS 8666:2005 Standard Shapes

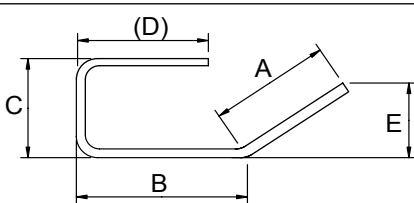
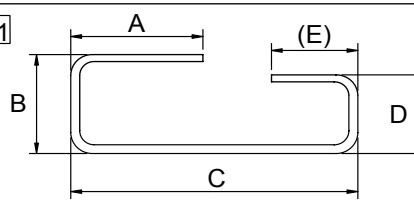
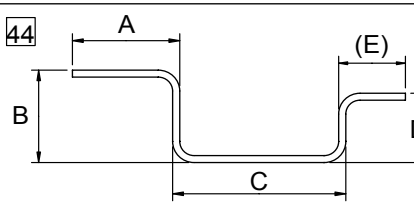
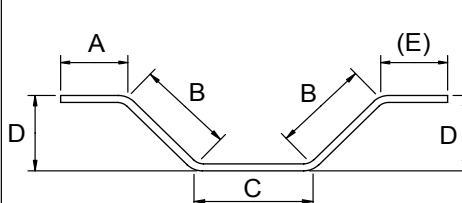
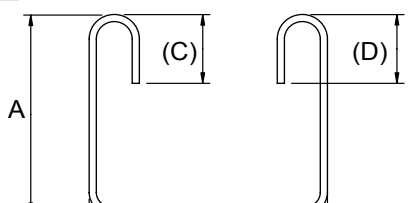
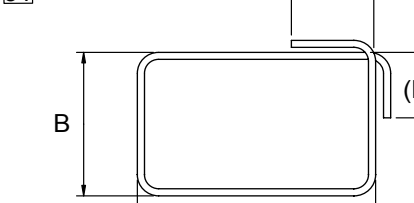
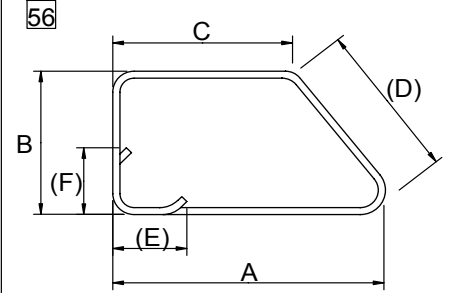
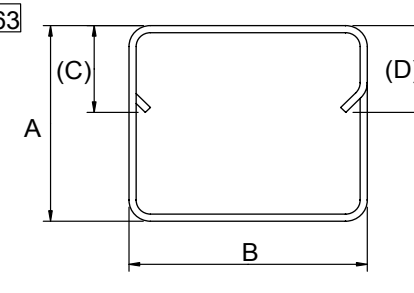
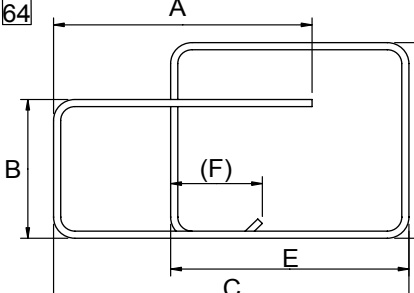
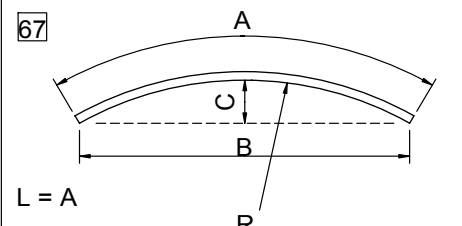
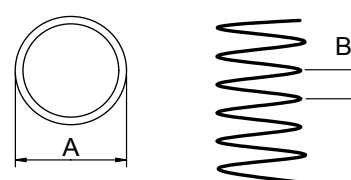
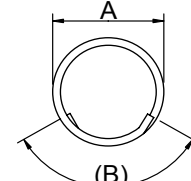
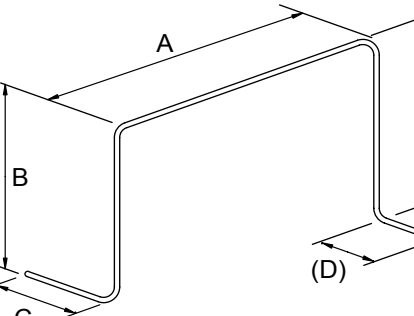
Shape and total length of bar (L) measured along centre-line		
<div style="border: 1px solid black; padding: 5px;"> <p>36</p>  <p>$L = A + B + C + (D) - r - 2d$</p> </div>	<div style="border: 1px solid black; padding: 5px;"> <p>41</p>  <p>$L = A + B + C + D + (E) - 2r - 4d$</p> </div>	<div style="border: 1px solid black; padding: 5px;"> <p>44</p>  <p>$L = A + B + C + D + (E) - 2r - 4d$</p> </div>
<div style="border: 1px solid black; padding: 5px;"> <p>46</p>  <p>$L = A + 2B + C + (E)$</p> </div>	<div style="border: 1px solid black; padding: 5px;"> <p>47</p>  <p>$L = 2A + B + \max(21d, 240)$ *see note</p> </div>	<div style="border: 1px solid black; padding: 5px;"> <p>51</p>  <p>$L = 2A + 2B + \max(16d, 160)$ *see note</p> </div>
<div style="border: 1px solid black; padding: 5px;"> <p>56</p>  <p>$L = A + B + C + (D) + 2(E) - 2.5r - 5d$</p> </div>	<div style="border: 1px solid black; padding: 5px;"> <p>63</p>  <p>$L = 2A + 3B + \max(14d, 150)$ *see note</p> </div>	<div style="border: 1px solid black; padding: 5px;"> <p>64</p>  <p>$L = A + B + C + 2D + E + (F) - 3r - 6d$</p> </div>
<div style="border: 1px solid black; padding: 5px;"> <p>67</p>  <p>$L = A$</p> </div>	<div style="border: 1px solid black; padding: 5px;"> <p>77</p>  <p>$C = \text{no. of turns}$</p> <p>$L = 3.14 (A - d) C$ where $B > A/5$ $L = \sqrt{\{(3.14 [A - d])^2 + B^2\}} C$</p> </div>	
<div style="border: 1px solid black; padding: 5px;"> <p>75</p>  <p>$L = 3.14 [A - d] + (B)$</p> </div>	<div style="border: 1px solid black; padding: 5px;"> <p>98</p>  <p>$L = A + 2B + C + (D) - 2r - 4d$</p> </div>	
<p>99</p> <p>All shapes where standard shapes cannot be used. No other shape code number, form of designation or abbreviation shall be used in scheduling. A dimensioned sketch shall be drawn over the dimension columns A to E. Every dimension shall be specified and the dimension that is to allow for permissible deviations shall be indicated in parenthesis, otherwise the fabricator is free to choose which dimension shall allow for the tolerance.</p>		<p>Notes The length equations for shape codes 47, 51 and 63 are for when dimensions C and D are to be minimised. '+ max(14 d, 150)' means add the greater value of either 14 d or 150mm.</p>

Also available from Inform UK ...



Aluminium Support Systems

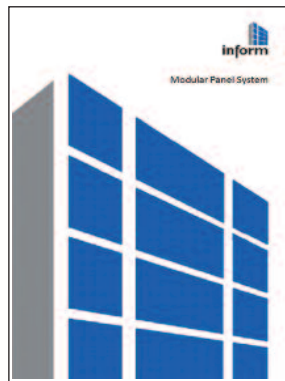

Small Panel Systems

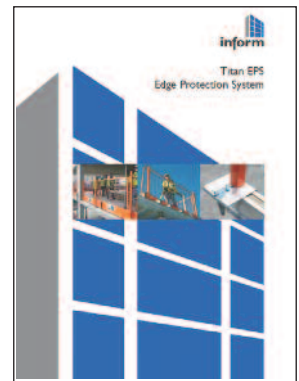

Edge Protection Systems

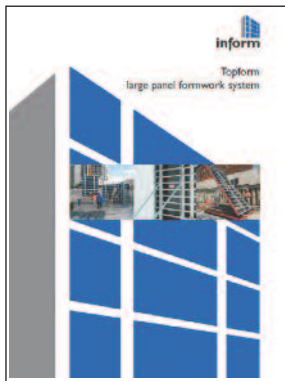

Large Panel Systems

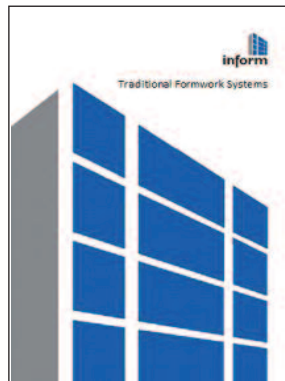

Traditional Formwork Systems

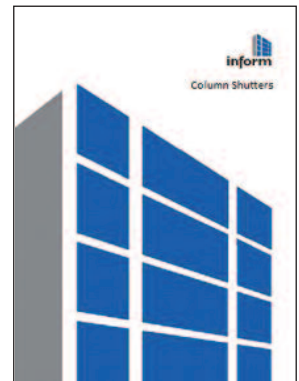

Column Shutters

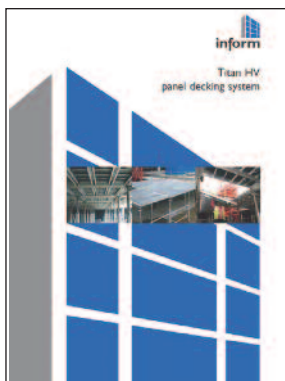

Modular Decking Systems



INFORM (UK) Ltd
Industrial Park
Ely Road
Waterbeach
Cambridge
CB25 9PG

Tel: 01223 862230 | Fax: 01223 440246
Web: www.informuk.co.uk | Email: general@informuk.co.uk